



本企业已通过ISO9001管理体系认证
中国缝纫机质量监督检验合格单位

JR6 系列
SERIES

高速平缝机
HIGH-SPEED LOCKSTITCH SEWING MACHINE

使用说明·零件手册
INSTRUCTIONS MANUAL& PARTS BOOK

*** 注意(图1) BEFORE OPERATION (FIG.1)**

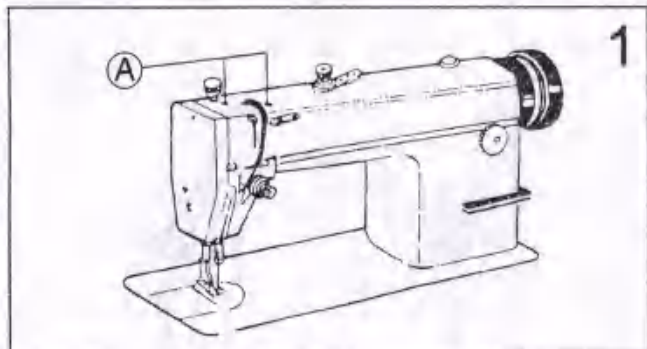

新机器在开始使用时,先卸下机头上部的橡皮塞A,充分加油,然后抬起压脚进行低速空转2000多转/分,观察油窗喷油情况,润滑正常后,仍须保持低速运转30分钟,以后逐步提高速度,充分磨合大约需一个月左右。

Pull out the nibber plug (A) before starting the machine, and fill enough oil. Lift the presser foot and pls take note of oil splashing through oil sight window when make the machine running at about 2000r.p.m.

After lubrication, pls keep low speed running about 30 minutes, and then enhance the speed accordingly.

2. 放梭油量调节(图3) ADJUSTING THE LUBRICATION OF ROTARY HOOK (FIG.3)

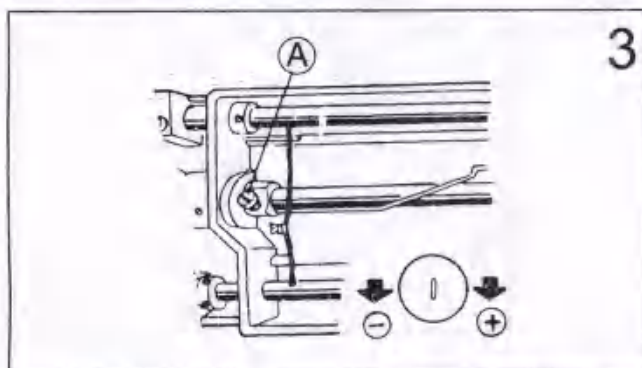

旋梭的油量,可以用油量调节螺钉A加以调节。按图示“+”号方向旋转,油量增加,“-”号方向旋转,油量减少。

The lubrication of the rotary hook can be adjusted by oil adjusting screw (A). Turn oil adjusting screw (A) to + to increase the oil and turn to - to decrease the oil.

4. 安装机针(图5) REPLACE NEEDLE (FIG.5)

将机针的长槽A朝向操作者的左面,把针柄插入针孔内,一定要接触到针杆孔的底部,再旋紧夹针螺钉,固定机针。

Keep the long groove of the needle leftward, insert the needle shank up to the bottom of the socket, then tighten the needle clamp screw and fix the needle.

1. 油盘注油(图2) LUBRICATION (FIG.2)

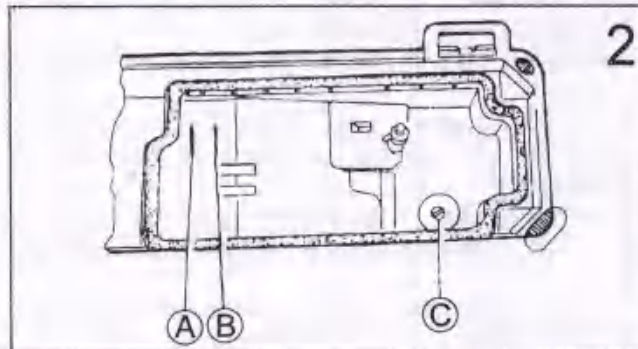

1、油量必须按油盘内标记加注,图中标记A是油量最高位,B是油量最低位,当油量下减到B以下时,请及时补充油量。

2、换油:旋松放油螺钉C,排净废油,打扫油盘污尘,旋紧放油螺钉C,加注新油。

※ 请使用本公司指定的特18#缝纫机油。

1. Required amount of oil line (A) on the oil reservoir max oil level. Line(B) on the oil reservoir: min oil level pls supply more oil when oil level goes down under line (B).

2. Oil charging: revolve screw(C) and release the rust-preventure oil and clean the oil pan. Tighten the screw(C) and libricate with new oil.

※ Pls use the 18# machine oil of the company.

3. 油泵进油调节(图4) LUBRICATION ADJUSTMENT (FIG.4)

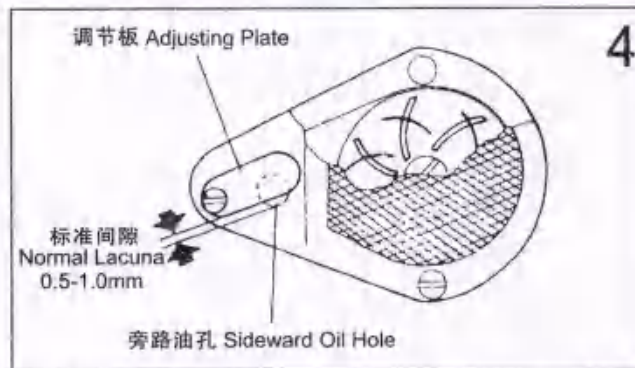

通常情况下,不作油泵进油调节,在低速运转时,观察油窗,未见油现象,请合拢间隙。

In ordinary operation, adjustment is not requirement for the oil pump. If oil splashing does not occur in the oil sight window, at low speed running, pls reduce the clearance of the by-pass hole.

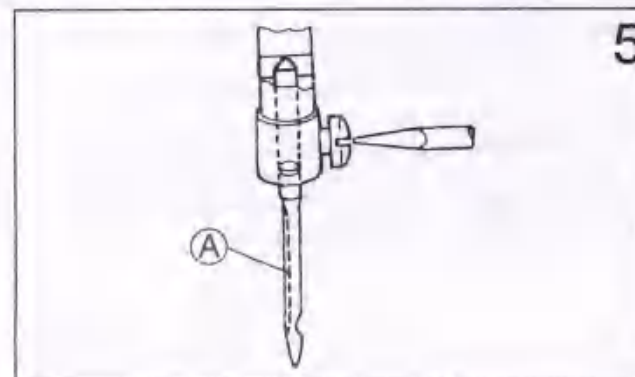

5. 踏脚板与离合器拉杆连接(图6) BAR(B) RUN IN LINE AS SHOWN IN (FIG.6)

- 1、踏脚板安装的倾斜度应与地面以15度为宜。
- 2、调整电动机离合器使缝纫机拉杆B与离合器拉杆C(如图6)连成一直线。
- 3、缝纫机转动方向,从机头主动轮外侧看,应是逆时针方向,与电动机转向一致。电动机转向可用电动机上的电源插头转换180度调整转向。
- 4、Z型皮带F的张力调整,由电动机移动上下位置来达到F皮带张力的大小,可用手指将皮带按下,使皮带如图示弯曲10-20毫米即可。

1) The optimum tilt angle of pedal is approximately is 15 degree.
2) Adjust clutch cover so that clutch lever (C) and Draw Bar (B) run in line as shown in Fig.6.

3) The balance wheel should rotate counter clockwise when viewed from the outside of balance wheel. The direction of the motor pulley rotation can be reversed by reversing turning over (80°) the power plug of the motor.

4) Adjust the tension of Z-belt (F) by turning motor vertical position screw. The proper tension of the Z-belt (F) is slack of 10-20mm when the belt is depressed at the center of the belt by finger.

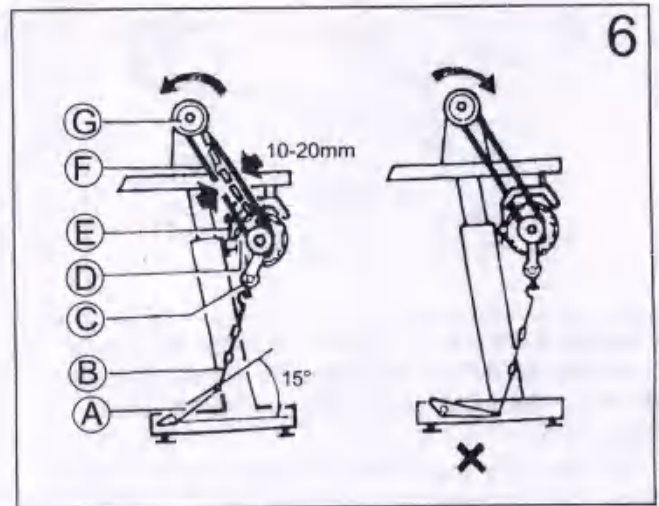

6. 安装皮带罩(图7) FIXING STRAP COVER(FIG.7)

从安全考虑,应安装皮带罩。
Strap cover should be fixed while considering safety.

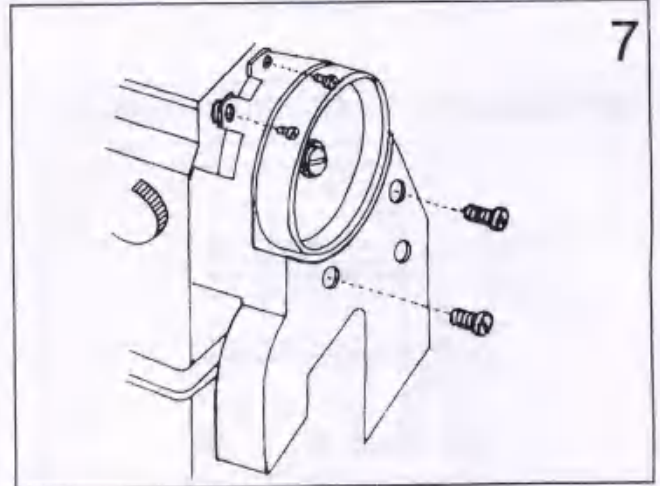

7. 松线器挺线调节(图8) LOOSENING THREAD MACHINE ADJUSTMENT (FIG.8)

压脚在提升范围,夹线器上的夹线板有一个张开期,挺线的时间可进行调节。调节时,先卸下机头背面的橡皮塞,用螺丝刀B旋松膝控提升杠杆(左)螺钉A,这时松线凸轮D可以左右移动,往右移挺线慢,往左移挺线快。

调节时,如有条件的话,在压脚C下垫上一块与压脚提升高度尺寸相等的垫块,则调节时方便。

Within the presser foot lift range, opening time of the tension discs can be adjusted as follows:

1) Remove the rubber plug from back of arm and loosen screw (A) of knee lifter lever (left).

2) Move the tension releasing can leftward for earlier opening or rightward for later opening. It will facilitate the adjustment to put under the presser foot a block as thick as the presser foot lift.

3) After the adjustment, fully tighten screw(A).

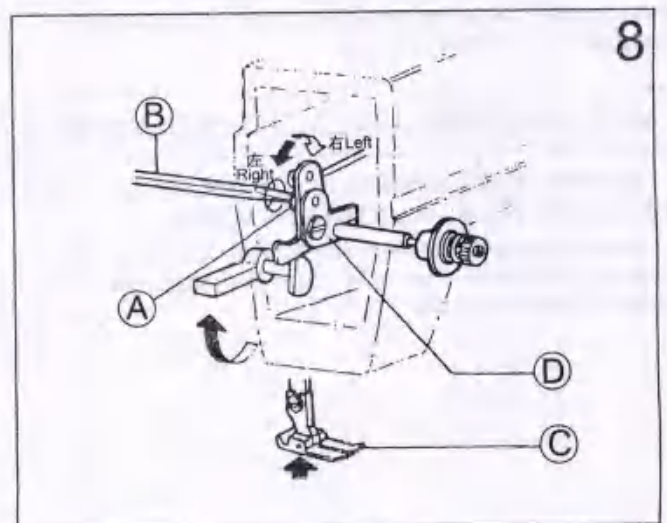

8. 穿线(图9) THREADING (FIG.9)

穿面线时挑线杆一般在最高位置，然后由线架上引出线头按顺序穿线。

引底线时，先将面线头捏住，转动主动轮使针杆向下运动，再回升到最高位置，然后拉起捏住的面线线头，底线即被牵引上来，最后将底、面二根线头一起置于压脚下前方。

To thread the needle thread, raise needle bar to the upper end of its stroke, lead the thread from spool and perform threading as shown in Fig.13.To draw the bobbin thread hold the end of the needle thread and turn the balance wheel to lower the needle bar and then to lift it to its highest position. Pull the needle thread and the bobbin thread is drawn up. Put the ends of needle thread and bobbin thread forward under presser foot.

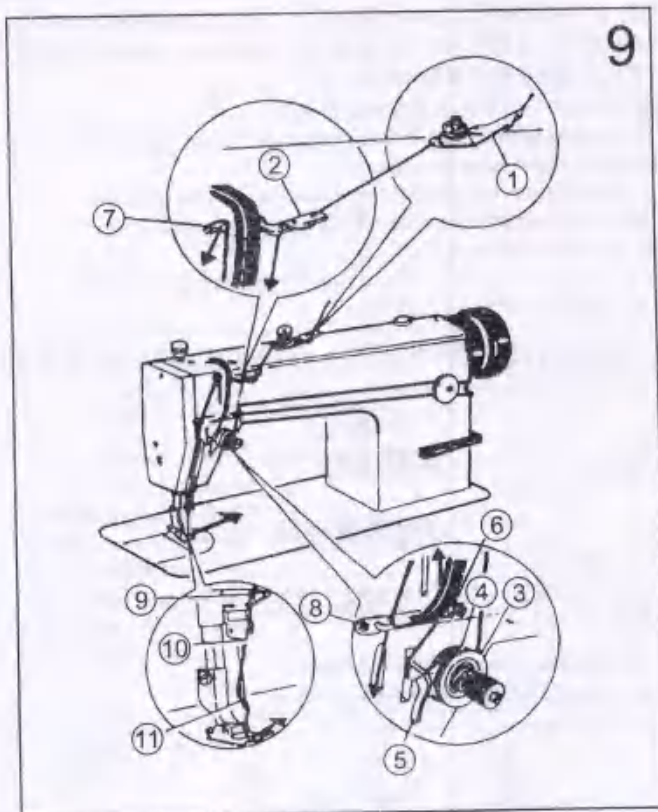

9. 安装绕线器及绕线方法(图10) BOBBIN WINDER ADJUSTMENT (FIG.10)

将绕线轮对准皮带的外边，其之间应有一定的空隙，保证按下绕线摆杆时，绕线轮和皮带能相互接触，机器转动时，皮带使绕线轮一起转动。

梭芯线应排列整齐而紧密。如松浮不紧，可以加大过线架夹线板A的压力，如排列不齐，则要移动过线架C的左右位置进行调整，单边绕线成图b时，向右移动过线架，单边绕线成C时，向左移动过线架。

适当的绕线量为平行绕线至梭芯外径的80%，绕线量由满线跳板上的满线调节螺钉E加以调节。

Make bobbin wheel aim at the outside of the strap, leave a space between them. Make sure when bobbin was pressed, the bobbin wheel and strap can be contacted, then when machine is working, strap can make bobbin wheel turning together.

The wound bobbin thread should be neat and tight, if not, adjust the winding tension by turning. Tension stud nut (A) of bobbin winder tension bracket.

The optimum length of thread will fill about 80% of bobbin capacity. This can be adjusted by adjusting screw (E) of bobbin winder stop latch.

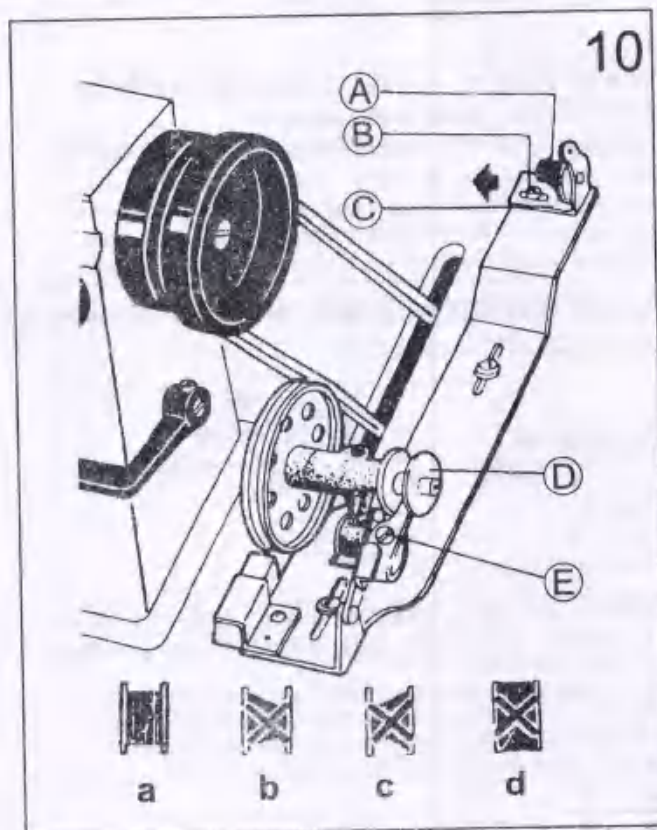

10. 压脚压力调节(图11) ADJUST THE PRESSURE OF PRESSER FOOT (FIG.11)

压脚的压力,要根据缝料的厚度加以调节。首先旋松调节螺钉锁紧螺母A,缝纫厚料时,应加大压脚压力,将机头顶部的调压螺钉向a所示方向转动。缝纫薄料时,向b所示的方向转动,以减小压脚的压力,最后旋紧调节螺钉锁紧螺母A。

压脚的压力,应以能正常推送缝料为宜。

Pressure of presser foot is to be adjusted in accordance with thickness of materials to be sewn.

First loosen lock nut (A) for heavy materials, turn the pressure regulating thumb screw as shown in fig (B) to decrease the pressure, then tighten lock nut (A).

The pressure of presser foot is recommended to be less as long as normal feeding is ensured.

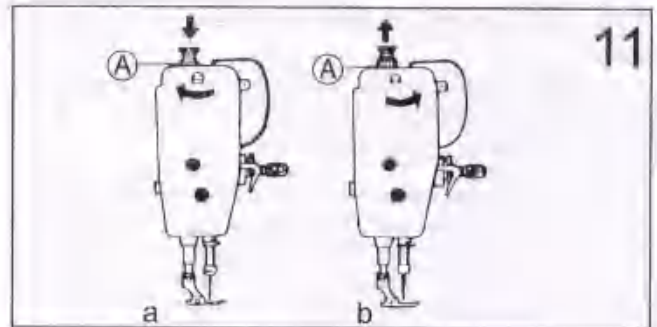

11

11. 线张力调节(图12.13.14) THREAD TENSION ADJUSTMENT (FIG.12,13,14)

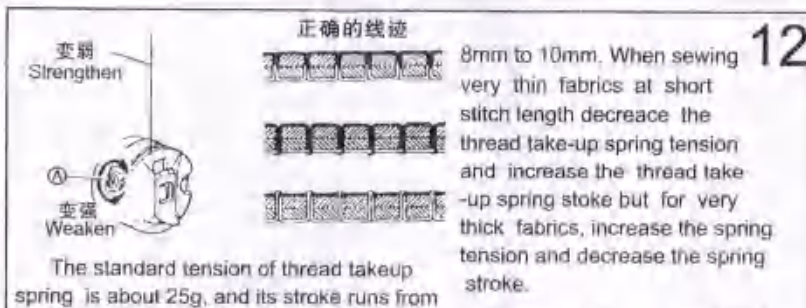

12

缝线的张力要依据缝纫出来的线迹,来调整底、面线的张力。

底线的张力:旋转梭芯套上橡皮螺钉A进行调节。梭芯装入梭芯套后,捏住线头,吊起梭芯套,梭芯套则能缓缓下落为宜。

面线张力:旋转夹线螺母进行调节。

Thread tension is adjusted according to the stitches obtained the needle thread tension should be adjusted with reference to the bobbin thread tension: Hold the end of the thread from delivery eye. If the bobbin case is falling slowly the proper tension is obtained.

The needle thread tension: circumrotale tension screw should be adjusted.

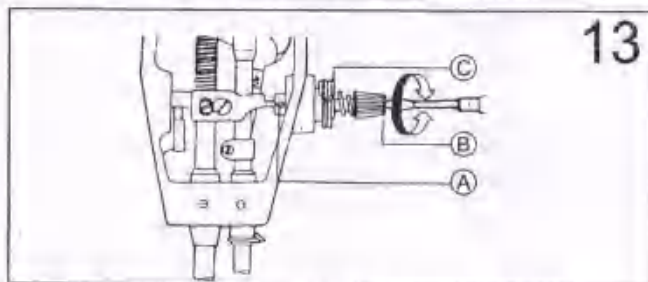

13

挑线簧摆动幅度为8-10毫米,缝纫薄料要减弱挑线簧的张力和放宽其摆动幅度,缝制特别厚的缝料则反之。

挑线簧张力调节方法:先旋松夹线调节螺钉A,夹线螺钉B就能转动,顺时针转动时,张力增加,反之则减少。

Adjusting the thread take-up spring tension: Loosen set screw (A), turn tension stud (B) clockwise to increase the spring tension. Or turn the stud counter-clockwise to decrease the spring tension.

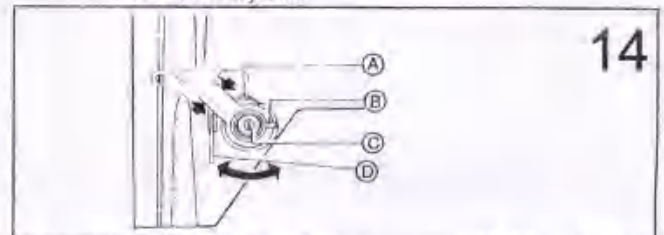

14

挑线簧摆动幅度的调节:旋松夹线调节座固定螺钉B,转动夹线器C,调节其摆动幅度,夹线器C顺时针转动,摆动幅度增大,反之则减少。

Adjusting the thread take-up spring stroke.

Loosen set screw (B), turn stud (C) clockwise to increase the stroke or turn stud (C) counter clockwise to decrease the stroke. After the adjustment tighten set screw (B). Before leaving the factory, the thread take-up spring has properly been adjusted. Readjustment is needed only in the case of special material or special thread.

12. 机针与旋梭的位置调整(图15.16) TIME NEEDLE TO ROTATING HOOK (FIG.15,16)

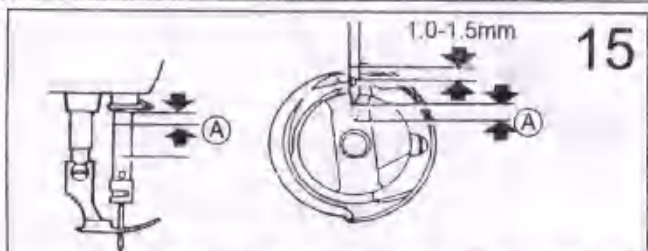

15

把针杆从最低位置上升到距离A时,旋梭的钩线尖D应与机针C的中心线重合。此时,钩线尖D应高于机针线孔上边1.0-1.5毫米。

Time needle to rotating hook.

The standard hook point timing is to align hook point D and needle centerline (C) should superposition when hook point rise to A from the lowest position. Besides, Hook point (D) should be 1.0-1.5mm above the upper end of needle eye (E).

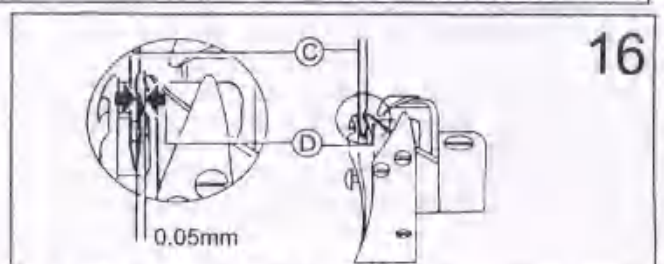

16

旋梭尖与机针的侧面间隙为0.05毫米。

The clearance between rotating hook point and hook point should be approx 0.05mm.

机 型	距 离 A	2.2mm	2mm	2.4mm

13. 针距、倒顺送料(图17) STITCH LENGTH, BACK FEED (FIG.17)

针距的长短，可以转动针距盘A来调节。针距标盘B上的数字表示针距长短尺寸（单位为毫米），调针距的同时，另一手要掀压操作杆C。

倒向送料时，将倒缝操作杆C，向下掀压，手旋松后，倒缝操作杆C自动复位，恢复顺向送料。

The stitch length can be adjusted by running stitch length tray-A. The figures on stitch length tray-B shows stitch length and size(mm). Another hand should hold the joy stick while adjusting stitch length.

Falling down the back-sewing joy stick when back feed. After loosening hand, the back-sewing joy stick will renew automatically and feed deasil.

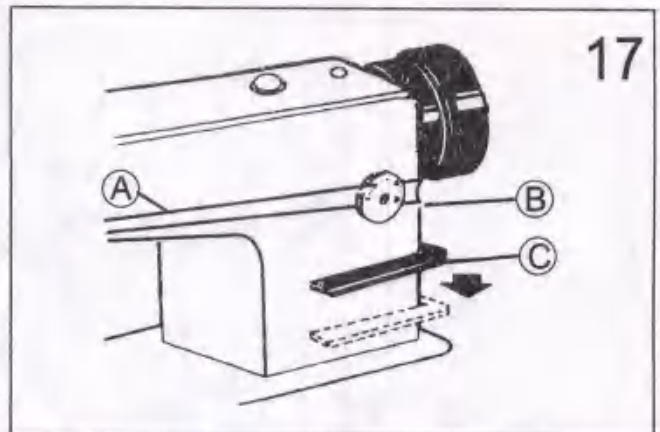

14. 送布牙与机针位置的调整(图18.19) ADJUSTING THE PLACE OF FEED DOG AND STITCH (FIG.18,19)

对送布牙G的位置调整，先松开凸轮两个螺钉F转动主动轮，使机针A的尖端，下降到针板面B时，送布牙C尖端与针板B高低一致，此为标准同步位置。调节完毕，拧紧螺钉F。

Adjusting the feed dog, should loosen two screw first and then running the driver, and make sure the stitch cusp fall to the stitch plate. It's in the standard space when the height of feed dog and stitch plate are consistent. After adjusting, tighten screw-F.

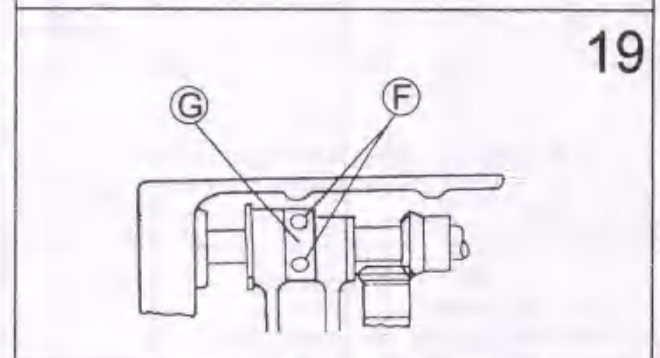
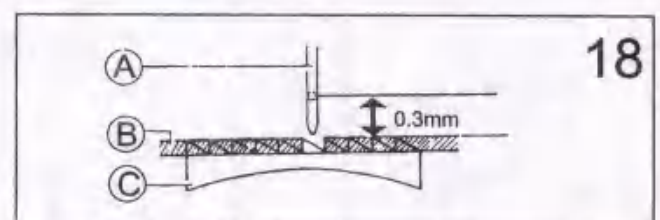

15. 倒顺针距误差调节(图20) ADJUSTING THE ERROR OF TOWARDS AND BACKWARDS STITCH LENGTH (FIG.20)

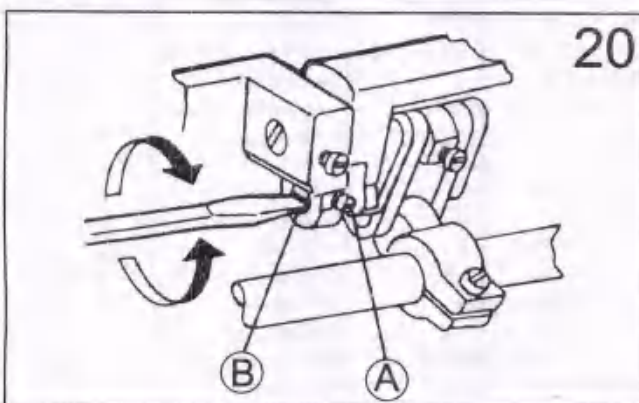

旋松螺钉A，旋转“连杆偏心轴”B，向右旋，顺缝针距变小，倒缝针距变大，向左旋，顺缝针距变大，倒缝针距变小。

Loosening screw-A and circumrotating "link lever partial shaft", if turned right, the deasil stitch length turn narrow; contrarily, back-sewing stitch length will turn narrow while deasil stitch length turn wide.

16. 送布牙倾斜调节(图21) FEED DOG INCLINE ADJUSTMENT (FIG.21)

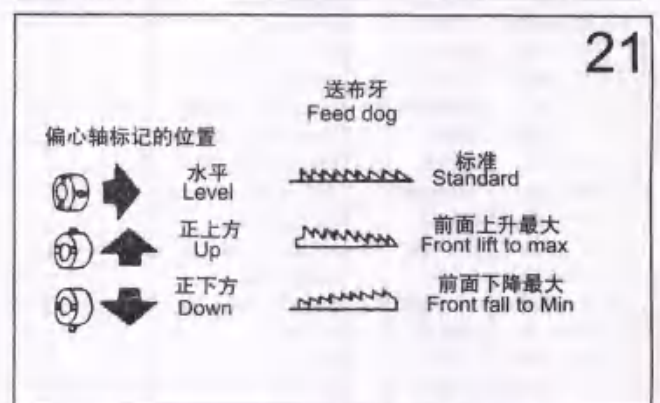

送布牙前面高时，可防止布料起缩，不容易出现空针，送布牙前面低时，可防止布料跑偏，底线不易断。

When the head of feed dog is higher, cloth can avoid shrinking, it's not easy to have empty done; reversely, it can avoid cloth deflect and the bottom thread is not easy to break.

摆梭

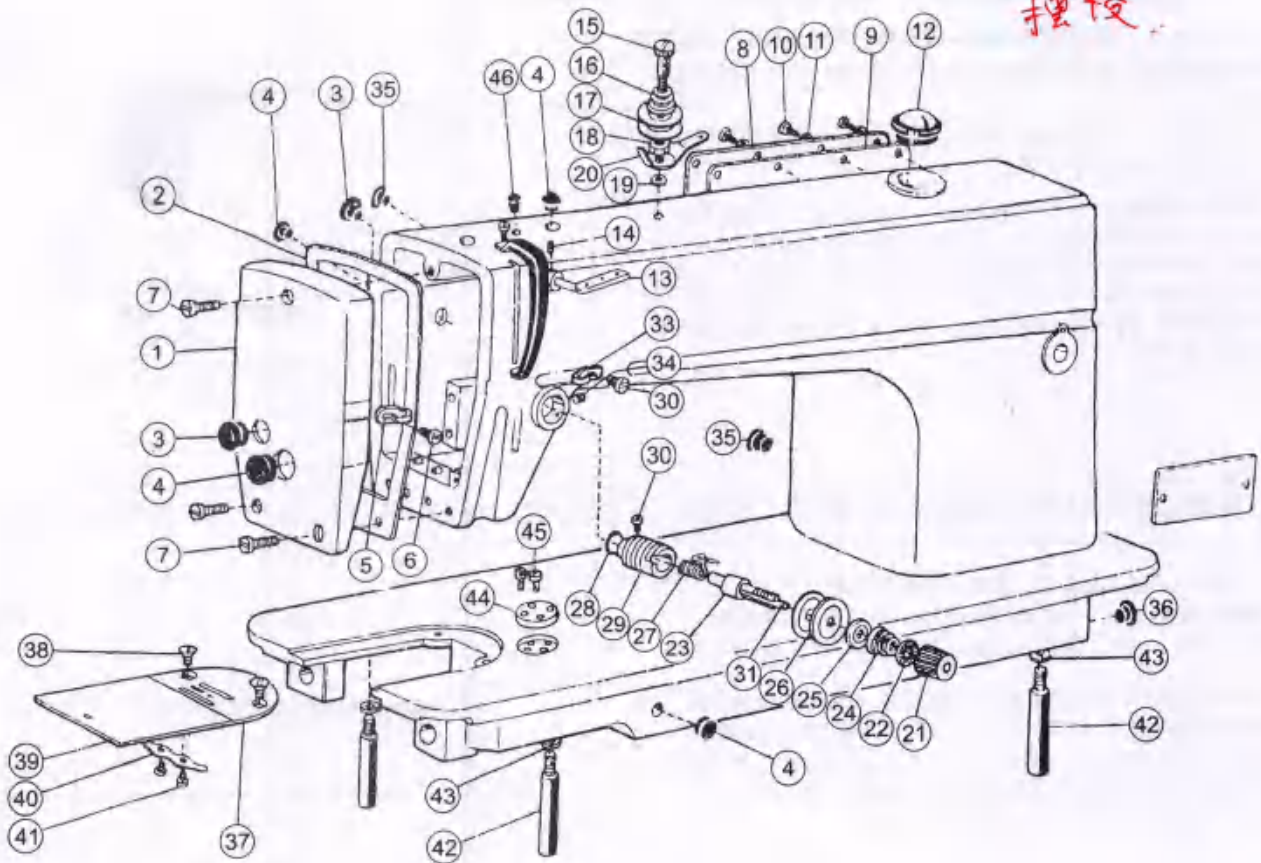

1. 机壳部件 COVER COMPONENTS

序号 Ref.No	图号 Part No.	名称	Name	件数Amt.Req.		
				M	H	B
1	124T1-002B1	面板	Face plate aim	1	1	1
2	124T1-002B2	面板垫片	Gasket	1	1	1
3	22T1-003C3	面板橡皮塞(Φ19)	Rubber plug (Φ19)	1	1	2
4	22T1-003C4	面板橡皮塞(Φ11.8)	Rubber plug (Φ11.8)	3	3	3
5	22T1-003C5	面板线钩	Screw	1	1	1
6	22T1-003C6	面板线钩螺钉	Thread eyelet screw	1	1	1
7	22T1-004	面板螺钉	Face plate screw	3	3	3
8	57T4-004B1	后盖板	Behind cover	1	1	1
9	22T1-005D2	后盖板垫片	Behind cover washerplate	1	1	1
10	22T1-006	后盖板螺钉	Behind cover screw	8	8	8
11	22T1-007	后盖板螺钉垫圈	Behind cover screw gasket	8	8	8
12	22T1-008H	油窗组件	Oil sight window components	1	1	1
13	22T1-010	三眼线钩	Three-hole thread eyelet	1	1	1
14	22T4-0B3	三眼线钩螺钉	Three-hole thread eyelet screw	1	1	1
15	22T1-009E1	小夹线螺钉	Small tension screw	1	1	1
16	22T1-009E2	小夹线弹簧	Small tension spring	1	1	1
17	22T1-009E3	小夹线板	Small tension disc	2	2	2
18	22T1-009E4	小夹线过线板垫块	Small tension disc gasket	1	1	1
19	GB896-76	开口挡圈	Snap ring	1	1	1
20	22T1-009E5	小夹线过线板	Small tension thread guide plate	1	1	1
21	124T1-003C1	夹线按钮	Tension button	1	1	1
22	22T1-012F10	夹线按钮止动片	Tension button stopper	1	1	1
23	22T1-012F1	夹线螺钉	Tension screw	1	1	1
24	124T1-003C2	夹线弹簧	Tension spring	1		
	48T1-003A1	夹线弹簧	Tension spring		1	1

序号 Ref.No	图号 Part No.	名称	Name	件数Amt.Req.		
				M	H	B
25	22T1-012F4	松线板	Tension disc holder	1	1	1
26	22T1-012F5	夹线板	Tension disc	2	2	2
27	22T1-012F6	携线簧	Take-up spring	1		
	48T1-003A2	携线簧	Take-up spring		1	1
28	22T1-012F11	O型圈	Rubber ring	1	1	1
29	22T1-012F7	夹线调节座	Tension set	1	1	1
30	22T1-012F8	夹线调节座螺钉	Tension set screw	1	1	1
31	22T1-012F9	松线钉	Thread release pin	1	1	1
32	22T1-013	夹线调节座固定螺钉	Tension set fixing screw	1	1	1
33	22T1-014	线钩	Thread eyelet	1	1	1
34	22T1-003C6	线钩螺钉	Thread eyelet screw	1	1	1
35	22T1-015	橡皮塞(Φ8.8)	Rubber (Φ8.8)	2	2	2
36	22T1-016	橡皮塞(Φ27)	Rubber (Φ27)	1	1	1
37	36T2-008	针板	Throat plate	1		
	48T1-004	针板	Throat plate		1	
	78T1-006	针板	Throat plate			1
38	22T1-020	针板螺钉	Throat plate screw	2	2	2
39	22T1-021G1	推板	Bed slide asm	1	1	1
40	22T1-021G2	推板簧	Bed slide spring	1	1	1
41	22T1-021G3	推板簧螺钉	Bed slide spring screw	2	2	2
42	48T1-005	底板撑杆	Bed plate stud	3	3	3
43	GB93-76	弹簧垫圈(按图6)	Spring ring	2	2	2
44	57T1-008	夹边座	Tension set	1	1	1
45	124T1-004	夹边座螺钉	Tension set screw	2	2	2
46	22T1-017	橡皮塞(Φ5.7)	Rubber (Φ5.7)	1	1	1

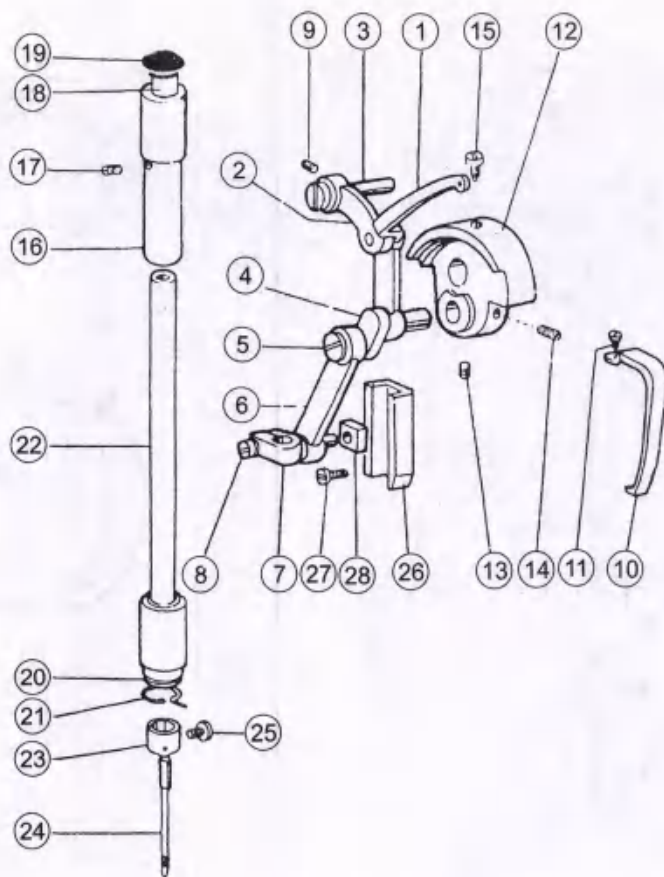

2. 针杆挑线部件 THREAD TAKE-UP COMPONENTS

序号 Ref. No	图号 Part No.	名称	Name	件数 Amt. Req.		
				M	H	B
1	124T2-001A1a	挑线杆组件	Thread take-up components	1		
	48T2-001A1a	挑线杆组件	Thread take-up components		1	
	78T2-001A1a	挑线杆组件	Thread take-up components			1
2	22T2-001A2	挑线连杆	Thread take-up lever link	1	1	1
3	124T2-001A2	挑线连杆铰链轴	Hinge shaft of jointed lever for osas stitching	1	1	1
4	124T2-001A3-1a	挑线曲柄	Thread take-up asm	1	1	
	124T2-001A3-1b	挑线曲柄	Thread take-up asm			1
	21T1-001A5	滚针轴承	Needle shaft bushing	2	2	2
5	22T2-001A6	挑线曲柄螺钉(左旋)	Screw (left twist)	1	1	1
6	22T2-001A7b1	针杆连杆	Needle bar crank rod	1		
	48T2-001A2	针杆连杆	Needle bar crank rod		1	1
7	22T2-001A8	针杆接头	Needle bar connecting rod	1	1	1
8	22T2-001A9	针杆接头螺钉	Screw	1	1	1
9	22T2-002	挑线连杆铰链轴螺钉	Screw	1	1	1
10	36T2-007	挑线杆防护罩	Thread take-up lever cover	1	1	
	78T2-002	挑线杆防护罩	Thread take-up lever cover			1
11	22T2-004	挑线杆防护罩螺钉	Screw	1	1	1
12	124T2-002B1a	针杆曲柄	Needle bar brace	1		
	124T2-002B1b	针杆曲柄	Needle bar brace		1	1
13	22T2-005B2	挑线曲柄螺钉	Screw	2	2	2
14	22T2-006	针杆曲柄螺钉	Screw	1	1	1

序号 Ref. No	图号 Part No.	名称	Name	件数 Amt. Req.		
				M	H	B
15	22T2-007	针杆曲柄定位螺钉	Screw	1	1	1
16	22T2-008	针杆轴套(上)	Needle bar bush (upper)	1	1	1
17	22T2-009	针杆轴套(上)螺钉	Screw	1	1	1
18	22T2-010	针杆轴套(上)毡塞	Felt plug of pin holder sleeve (up)	1	1	1
19	22T2-011	橡皮塞(φ8.8)	Robber plug	1	1	1
20	22T2-012C1	针杆轴套(下)	Needle bar bush lower	1		
	78T2-003	针杆轴套(下)	Needle bar bush lower		1	1
21	22T2-012C2	针杆轴套(下)过线勾	Needle bar thread guide	1	1	1
22	22T2-014	针杆	Needle bar	1		
	48T2-003	针杆	Needle bar		1	1
23	22T2-015	针杆过线环	Overpassing ring of pin holder	1		
	48T2-004	针杆过环	Overpassing ring of pin holder		1	1
24	22T2-016	机针(DB x 1) 14#	Need (DBx1) 14#	1		
		机针(DB x 5)	Need (DPx5)		1	1
25	22T2-017	针尖螺钉	Screw	1	1	1
26	22T2-018	针杆接头滑块导轨	Joint slideway of pin holder	1	1	1
27	22T2-019	滑块导轨螺钉	Screw of slideway	2	2	2
28	22T2-020	针杆接头滑块	Slide block	1	1	1

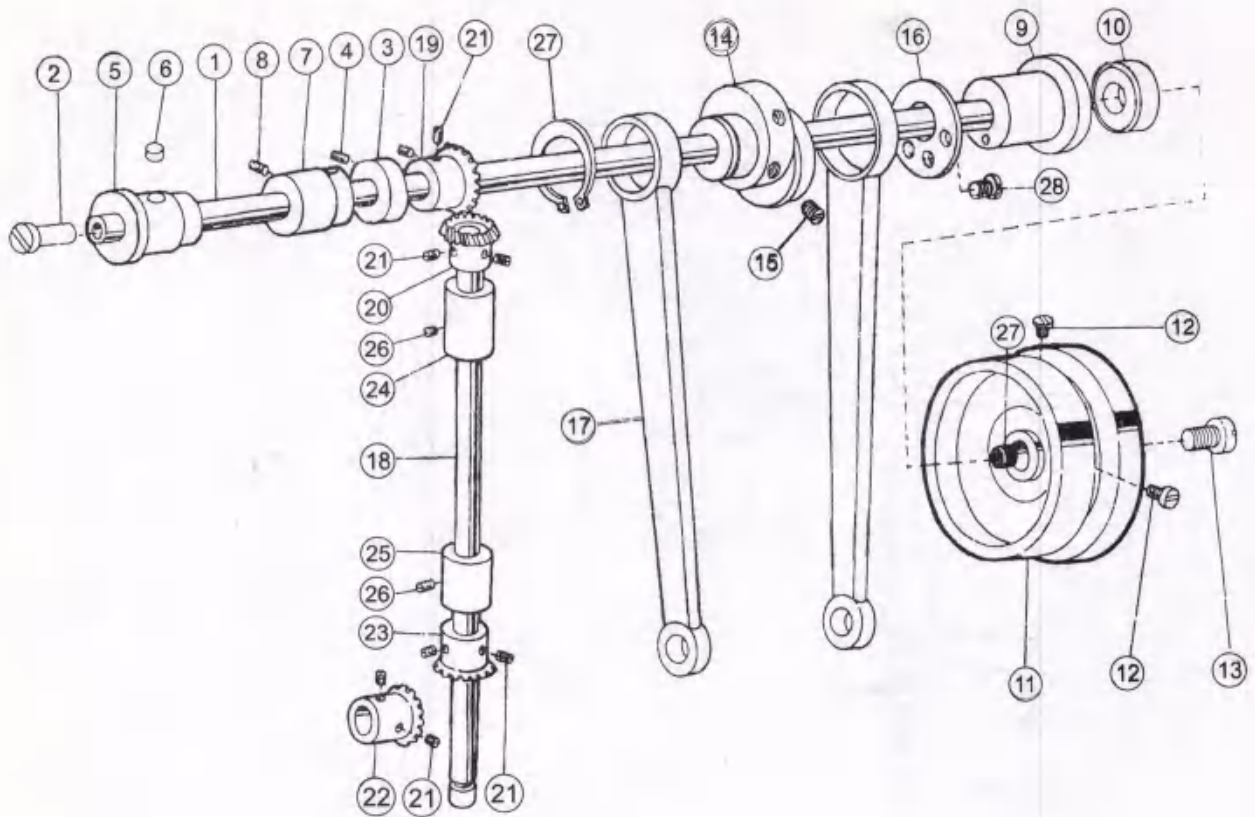

3. 上轴竖轴部件MAIN SHAFT & upright shaft

序号 Ref. No	图号 Part No.	名称	Name	件数Amt. Req.		
				M	H	B
1	124T3-001A1	上轴	Main shaft	1	1	1
2	124T3-001A2	上轴橡皮塞(Φ7.4X10)	Screw	1	1	1
3	22T3-002B1	上轴紧圈	Thrust collar asm	1	1	1
4	22T3-002B2	上轴紧圈螺钉	Screw	2	2	2
5	124T3-002B1	上轴左轴套	Main shaft bush (left)	1	1	1
6	124T3-002B2	油毡	Asphalt felt	1	1	1
7	22T3-004	上轴轴套(中)	Main shaft bush (middle)	1	1	1
8	22T2-002	上轴轴套(中)螺钉	Screw	1	1	1
9	124T3-003C1	上轴右轴套	Main shaft bush (right)	1	1	1
10	124T3-003C2	上轴右轴套油封	Hand wheel	1	1	1
11	36T3-002C1	主动轮	Screw	2	2	2
12	22T3-007C2	主动轮螺钉	End screw	1	1	1
13	22T3-008	上轴油封螺钉	Cam	1		
14	36T3-003	凸轮	Cam		1	1
	114T3-001	凸轮				

序号 Ref. No	图号 Part No.	名称	Name	件数Amt. Req.		
				M	H	B
15	22T1-013	凸轮螺钉	Screw of cam	1	1	1
	22T5-001A4	凸轮螺钉	Screw of cam	1	1	1
16	36T3-004	凸轮挡板	Plate of cam	1	1	1
17	22T3-009D1C	拾牙连杆	Connecting rod	1	1	1
18	22T3-010E1	竖轴	Upright shaft	1	1	1
19	22T3-010E2a1-2	上轴伞齿轮(Z=27)	Gear asm	1	1	1
20	22T3-010E2a2-2	竖轴上伞齿轮(Z=18)	Pinion asm(upper)	1	1	1
21	22T2-005B3	伞齿轮螺钉	Screw	8	8	8
22	22T3-010E2b1-2	下轴伞齿轮(Z=21)	Pinion asm(lower)	1	1	1
23	22T3-010E2b2-2	竖轴下伞齿轮(Z=28)	Gear asm(lower)	1	1	1
24	22T3-011	竖轴轴套(上)	Bush (upper)	1	1	1
25	22T3-011	竖轴轴套(下)	Bush (lower)	1	1	1
	78T3-001	竖轴轴套(下)	Bush (lower)			1
26	22T2-002	竖轴轴套螺钉	Screw	2	2	2
27	22T3-009D1b	拾牙连杆挡圈	Collar of feed driving connecting rod	1	1	1
28	100T6-012	送布凸轮挡板螺钉	Screw	3	3	3

M. 41 皮带,

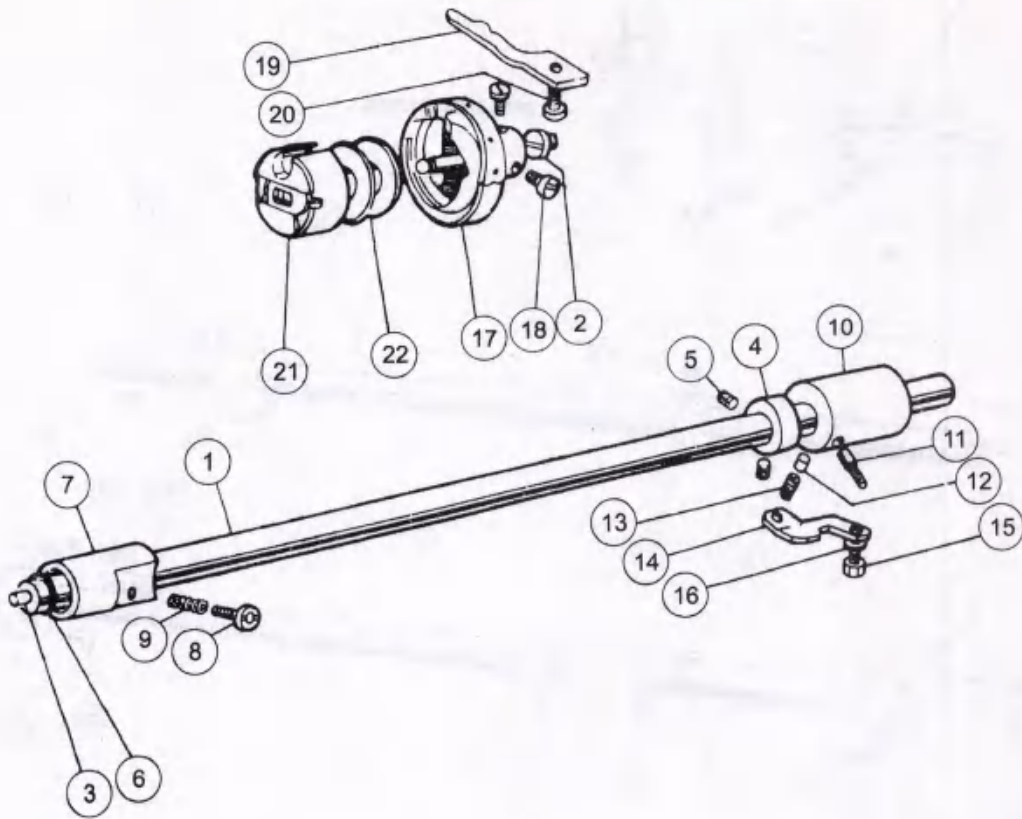

4. 勾线部件HOOK DRIVING SHAFT COMPONENTS

序号 Ref.No	图号 Part No.	名称	Name	件数Amt.Req.		
				M	H	B
1	36T4-008D1	下轴	Hook driving shaft	1	1	
	120T4-001	下轴	Hook driving shaft			1
2	22T4-001A1a1	下轴滤油塞螺钉	Oil seal screw	1	1	1
3	22T4-001A1a2	下轴滤油塞	Oil seal	1	1	2
4	22T4-002B1	下轴紧圈	Thrust collar asm	1	1	1
5	22T2-009	下轴紧圈螺钉	Screw	2	2	1
6	22T4-003G	下轴油封	Thrust collar asm	1	1	1
7	22T4-004	下轴轴套(左)	Hook driving shaft (left)	1	1	1
8	22T4-005	油量调节螺钉	Oil adjusting screw	1	1	1
9	22T4-006	油量调节弹簧	Oil adjusting spring	1	1	1
10	34T4-014F1	下轴轴套(右)	Hook driving shaft (right)	1	1	1
11	22T4-007C2	下轴轴套油管	Oil pipe	1	1	1
12	34T4-015	柱塞	Plunger	1	1	1
13	34T4-016	柱塞弹簧	Plunger spring	1	1	1
14	22T4-010	挡板	Guard plate	1	1	1
15	22T8-009	挡板螺钉	Screw			

序号 Ref.No	图号 Part No.	名称	Name	件数Amt.Req.		
				M	H	B
16	GB93-76	挡板螺钉弹簧垫圈	Spring washer	1	1	1
17	22T4-011D	旋梭组件	Hook component	1		
	48T4-001A	旋梭组件	Hook component		1	
	78T4-002	旋梭组件	Hook component			1
18		旋梭螺钉	Screw	2	2	2
19	22T4-013	旋梭定位钩	Hook set guide	1		
	48T4-002	旋梭定位钩	Hook set guide		1	
	78T4-003	旋梭定位钩	Hook set guide			1
20	22T4-015	旋梭定位钩组件	Screw	1	1	1
21	22T4-016F	梭芯套组件	Bobbin bushing components	1	1	
	78T4-004F	梭芯套组件	Bobbin bushing components			1
22	22T4-017	梭芯	Bobbin	1	1	
	78T4-005	梭芯	Bobbin			1

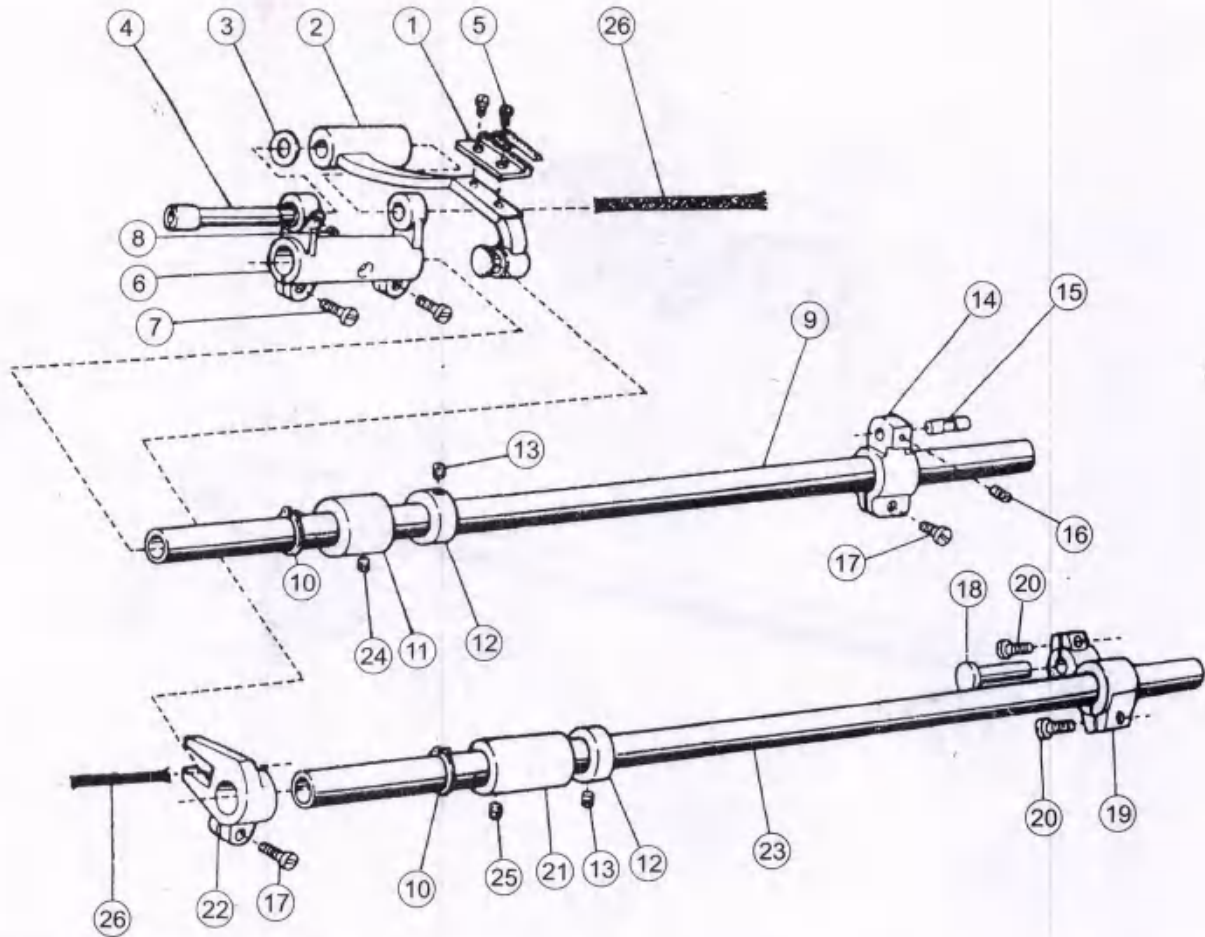

5. 送布部件FEED MECHANISM COMPONENTS

序号 Ref.No	图号 Part No.	名称	Name	件数Amt. Req.		
				M	H	B
1	22T6-001A3	送布牙	Feed dog	1		
	48T6-001A2	送布牙	Feed dog		1	1
2	36T4-001A1a	牙架小组件	Feed bar component	1	1	1
3	22T6-001A6	牙架垫圈	Feed bar washer	1	1	1
4	36T4-001A2	牙架曲柄偏心轴	Feed dog asm shaft	1	1	1
5	22T6-001A4	送布牙螺钉	Feed dog screw	2	2	2
6	22T6-001A1a	牙架曲柄	Feed driving rocker	1		
	48T6-001A1a	牙架曲柄	Feed driving rocker		1	1
7	22T6-001A1b	牙架曲柄螺钉	Screw	2	2	2
8	22T2-019	牙架曲柄轴螺钉	Screw	1	1	1
9	36T4-002	送布轴	Feed rocker shaft	1	1	1
10	GB894-76	轴用弹性挡圈	Retaining ring	2	2	2
11	124T6-001	送布轴轴套	Feed rocker shaft bushing	1	1	1
12	22T6-005B1	送布轴紧圈	Thrust collar asm	2	2	2
13	22T3-002B2	送布轴紧圈螺钉	Screw	4	4	4

序号 Ref.No	图号 Part No.	名称	Name	件数Amt. Req.		
				M	H	B
14	36T4-003	送布轴曲柄(右)	Feed rocker shaft crank asm (right)	1		
	114T4-001	送布轴曲柄(左)	Feed rocker shaft crank asm (right)		1	1
15	36T4-004H01	曲柄连杆短销	Pin	1	1	1
16	36T5-008E5	曲柄连杆短销螺钉	Screw	1	1	1
17	22T6-008D3	曲柄夹紧螺钉	Screw	2	2	2
18	22T6-007	拾牙轴曲柄铰链轴	Gemel shaft	1	1	1
19	36T4-017	拾牙曲柄(右)	Feed driving shaft asm	1	1	1
	J0.0.71	拾牙曲柄螺钉	Screw	2	2	2
21	22T6-012	拾牙曲套(左)	Thrust collar bush (left)	1	1	1
22	36T4-018H1D1	拾牙叉	Feed driving fork	1	1	1
23	36T4-018H2	拾牙轴	Feed driving shaft	1	1	1
24	22T2-009	送布轴轴套螺钉	Screw	1	1	1
25	22T2-002	拾牙轴套螺钉	Screw	1	1	1
26	36T4-001A3	油线	Oil thread	2	2	2

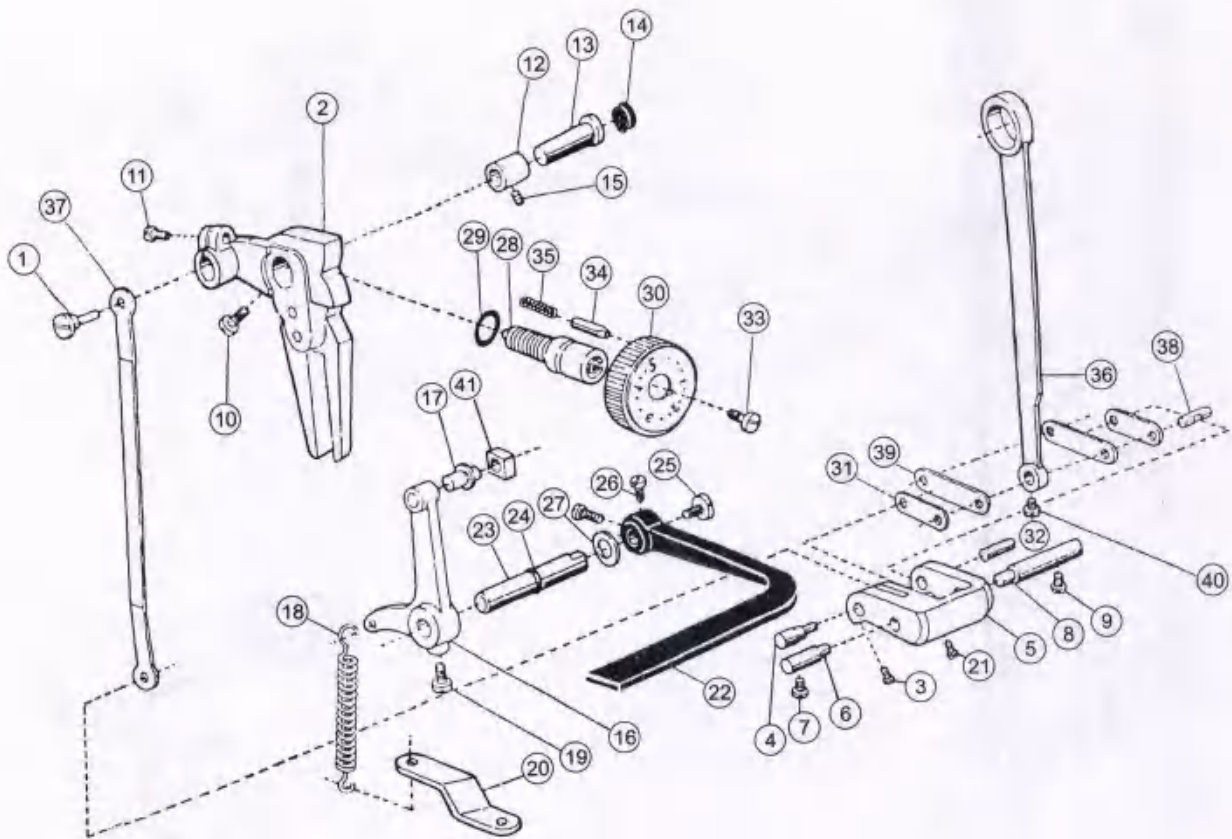

6. 送布调节部件FEED ADJUSTMENT COMPONENTS

序号 Ref. No.	图号 Part No.	名称	Name	件数Amt. Req.		
				M	H	B
1	36T5-001	针距调节连杆螺钉	Stitch length adjusting link lever screw	1	1	1
2	57T5-001	针距座	Stitch length set	1		
	124T5-002	针距座	Stitch length set		1	1
3	36T5-008E8	连杆偏心轴螺钉	Link lever partial shaft screw	1	1	1
4	36T5-008E9	连杆偏心轴	Link lever partial shaft	1	1	1
5	36T5-008E10	针距调节手柄	Stitch length adjusting handle	1	1	1
6	36T5-009H02	针距调节手柄定位销(左)	Stitch length adjusting handle pinching screw (left)	1	1	1
7	22T6-008D3	左定位销螺钉	Left pinching screw	1	1	1
8	36T5-009H01	针距调节手柄定位销(右)	Stitch length adjusting handle pinching screw (right)	1	1	1
9	22T6-008D3	右定位销螺钉	Right pinching screw	1	1	1
10	22T5-010D4	针距座螺钉	Stitch length set screw	1	1	1
11	22T2-019	针距座夹紧螺钉	Stitch length set tension screw	1	1	1
12	22T5-003	针距座轴套	Stitch length set shaft sheath	1	1	1
13	22T5-004	针距座轴	Stitch length set shaft	1	1	1
14	36T5-003	橡皮塞(φ20)	Rubber (φ20)	1	1	1
15	22T2-002	针距座轴套紧固螺钉	Stitch length set shaft sheath tension screw	1	1	1
16	22T5-012E1	倒缝操纵杆手柄	Back-sewing joy stick handle	1	1	1
17	22T5-012E1a1	操纵杆手柄滑块轴	Joy stick handle pulling shaft	1	1	1
18	57T5-004B1	操纵杆手柄拉簧	Joy stick handle pulling spring	1	1	1
19	22T5-013	操纵杆手柄螺钉	Joy stick handle screw	1	1	1
20	57T5-005	拉簧架	Pulling spring shell	1	1	1
21	36T5-008E7	短连杆销螺钉	Short stitch length screw	1	1	1

序号 Ref. No.	图号 Part No.	名称	Name	件数Amt. Req.		
				M	H	B
22	36T5-006C2	倒缝操纵杆	Reverse feed control lever	1	1	1
23	36T5-006C1a1	倒缝操纵杆短轴	Feed reverse shaft(short)	1	1	1
24	GB1235-76	O型密封圈	Rubber ring	1	1	1
25	22T5-010D3	倒缝操纵杆吊架螺钉	End screw	1	1	1
26	22T5-010D4	倒缝操纵杆螺钉	Screw	2	2	2
27	22T5-011	倒缝操纵杆垫圈	Washer	1	1	1
28	124T5-001A2	针距调节螺杆	Feed regulator screw	1	1	1
29	22T5-006C4	O型橡胶圈	Rubber ring	1	1	1
30	124T5-001A1-1	针距旋轮	Feed dial	1		
	124T5-001A1-2	针距旋轮	Feed dial	1	1	1
31	36T5-008W4H01	曲柄短连杆	connecting link	1	1	1
32	36T5-008E6	曲柄短连杆销	Walking foot pin	1	1	1
33	22T5-006C3	针距旋轮螺钉	Stitch dial rubber	1	1	1
34	22T5-008	止动销	Stopper pin	1	1	1
35	22T5-009	止动销弹簧	Stopper pin spring	1	1	1
36	36T5-008E2	送布连杆	Connecting rod	1	1	1
37	36T5-008E3	针距调节连杆	Bar	1	1	1
38	36T4-004H02	曲柄连杆长销	Walking foot pin	1	1	1
39	36T5-008E4H02	曲柄长连杆	Walking foot link	2		
	114T5-003	曲柄长连杆	Walking foot link		2	2
40	36T5-008E5	送布连杆螺钉	Screw	1	1	1
41	22T5-012E1a2	操纵杆手柄滑块	Slip block	1	1	1

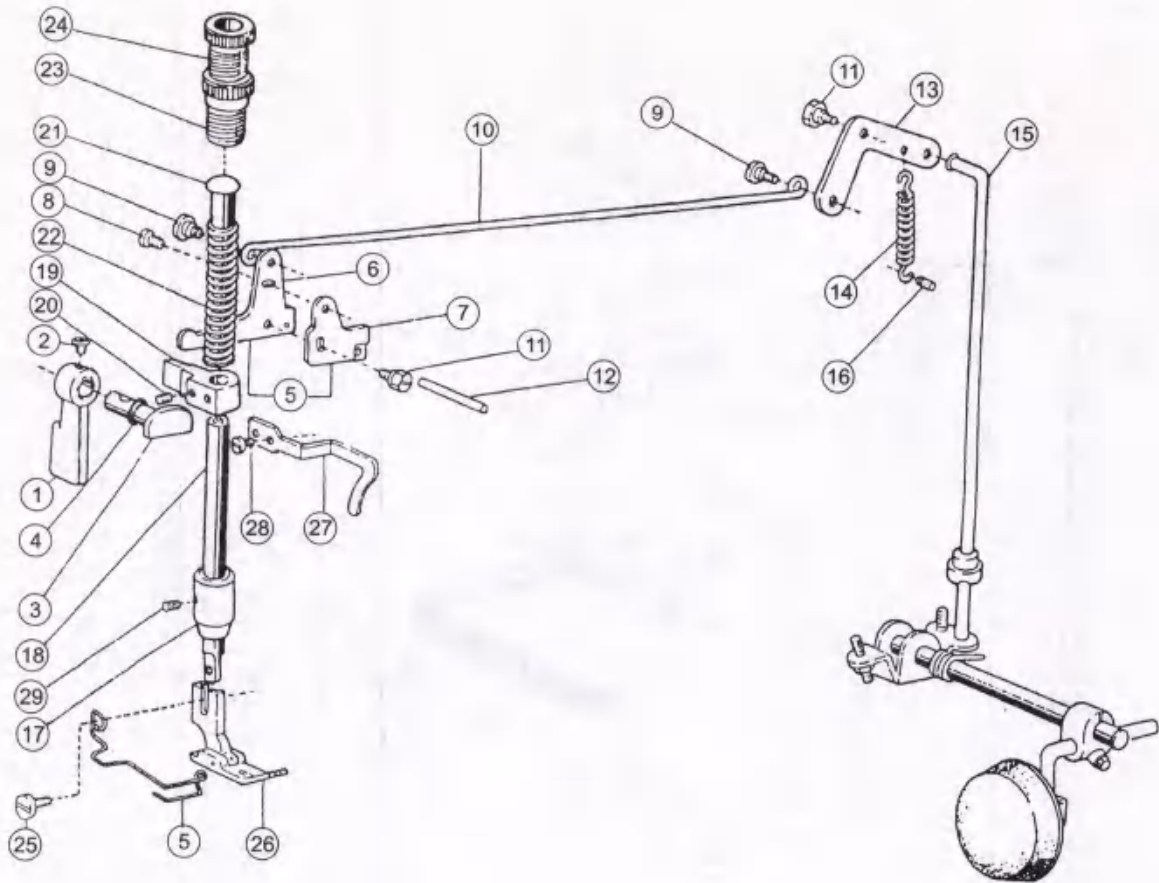

7. 压脚部件PRESSER COMPONENTS

序号 Ref.No	图号 Part No.	名称	Name	件数Amt. Req.		
				M	H	B
1	22T7-001A1	压脚扳手	Hand lifter lever	1	1	1
2	22T1-006	压脚扳手螺钉	Hand lifter lever screw	1	1	1
3	22T7-002	压紧杆提升凸轮	Hand lifter cam asm	1	1	1
4	GB1235-76	压紧杆提升凸轮油封	Rubber ring	1	1	1
5	57T7-002	压脚护簧	Hand lifter protecting spring	1	1	1
6	22T7-004B1a	膝控提升杆(左)	Lifting lever link shaft (left)	1	1	1
7	22T7-004B1b	松线凸轮	Tension release plate	1	1	1
8	22T7-004B1c	膝控提升杆(左)螺钉	Lifting lever link shaft screw (left)	1	1	1
9	22T7-004B2	铰链螺钉	Screw	2	2	2
10	22T7-004B3	膝控提升拉杆	Lifting lever connecting rod	1	1	1
11	22T7-005	松线凸轮螺钉	Tension released plate screw	1	1	1
	22T7-005	膝控提升杆(右)螺钉	Tension released plate screw	1	1	1
12	22T7-006	松线杆	Release rod	1	1	1
13	22T7-007C1	膝控提升杆(右)	Lifting lever link shaft (right)	1	1	1
14	22T7-007C2	膝控提升杆(右)弹簧	Lifting lever link shaft spring (right)	1	1	1
15	22T7-007C3	膝控提升连杆	Lifting lever connecting rod	1	1	1

序号 Ref.No	图号 Part No.	名称	Name	件数Amt. Req.		
				M	H	B
16	22T7-008	弹簧销	Spring pin	1	1	1
17	22T7-009	压紧杆轴套	Pressing lever shaft bushing	1	1	1
18	22T7-010	压紧杆	Pressing lever	1	1	1
19	22T7-011D1	压紧杆导架	Guided bracket for pressing lever	1	1	1
20	22T1-013	压紧杆导架螺钉	Guided racks screw of pressing lever	1	1	1
21	22T7-012	压紧杆弹簧导柱	Guided pole	1	1	1
22	22T7-013	压紧杆弹簧	Spring of pressing lever	1		
	48T7-002	压紧杆弹簧	Spring of pressing lever		1	1
23	22T7-014E1	调压螺钉	Presser spring regulator	1	1	1
24	22T7-014L2	调压螺钉锁紧螺母	Nut	1	1	1
25	22T7-015	压脚螺钉	Hand lifter screw	1	1	1
26	22T7-017F	压脚组件	Presser components	1		
	48T7-003A	压脚组件	Presser components	1	1	1
27	38T6-009	大线勾	Line hook	1	1	1
28	22T2-004	大线勾螺钉	Screw	1	1	1
29	22T2-013	压紧杆轴套螺钉	screw	1	1	1

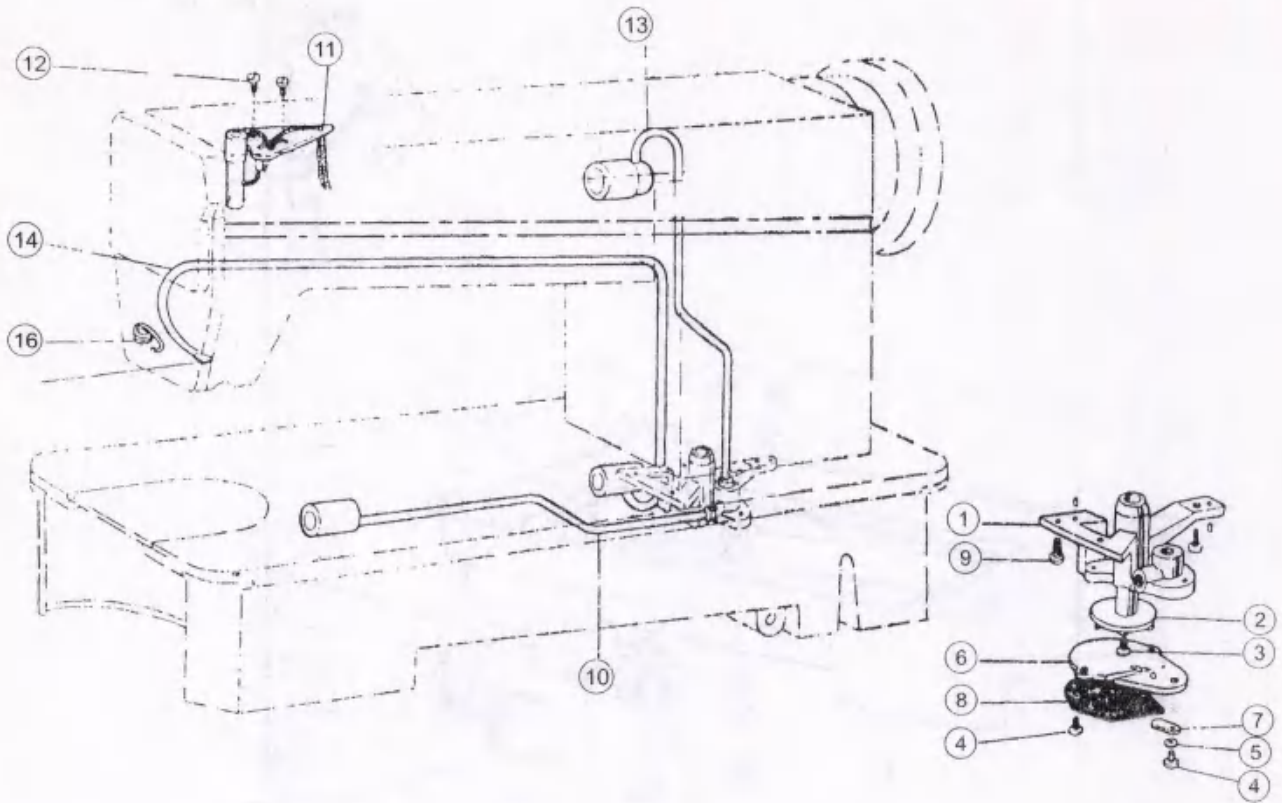

8. 油泵部件 OIL PUMP ASM

序号 Ref No	图号 Part No.	名称	Name	件数 Amt. Req.		
				M	H	B
1	22T8-001	油泵体	Oil pump	1	1	1
2	22T8-002	油泵叶轮	Oil pump impeller	1	1	1
3	22T8-003	油泵叶轮螺钉	Oil pump impeller screw	1	1	1
4	22T8-004	油泵调节板螺钉	Oil pump adjusting base	3	3	3
5	22T8-005	油泵调节板螺钉弹簧垫圈	Spring gasket	1	1	1
6	22T8-006	油泵体盖板	Lubricating oil pump cover	1	1	
	78T8-001	油泵体盖板	Lubricating oil pump cover			1
7	22T8-007	油量调节板	Oil adjusting plate	1	1	1
8	22T8-008	油泵滤网组件	Oil pump filter asm	1	1	1

序号 Ref No	图号 Part No.	名称	Name	件数 Amt. Req.		
				M	H	B
9	22T8-009	油泵体螺钉	Oil pump screw	3	3	3
10	22T8-010B	下输油管组件	Lower shaft oil tube	1	1	1
11	124T8-001A	油线固定板组件	Components of locating board for oil line	1	1	1
12	22T8-012	油线固定板螺钉	Screw of locating board for oil line	2	2	2
13	22T8-013D	上输油管组件	Upper shaft oil tube components	1	1	
	78T8-002A	上输油管组件	Upper shaft oil tube components	1	1	1
14	22T8-014	回油管	Oil return tube	1	1	1
15	22T8-015	回油管滤油毡	Tapis of oil return tube	1	1	1
16	36T10-002	回油管夹	Oil return tube holder	1	1	1

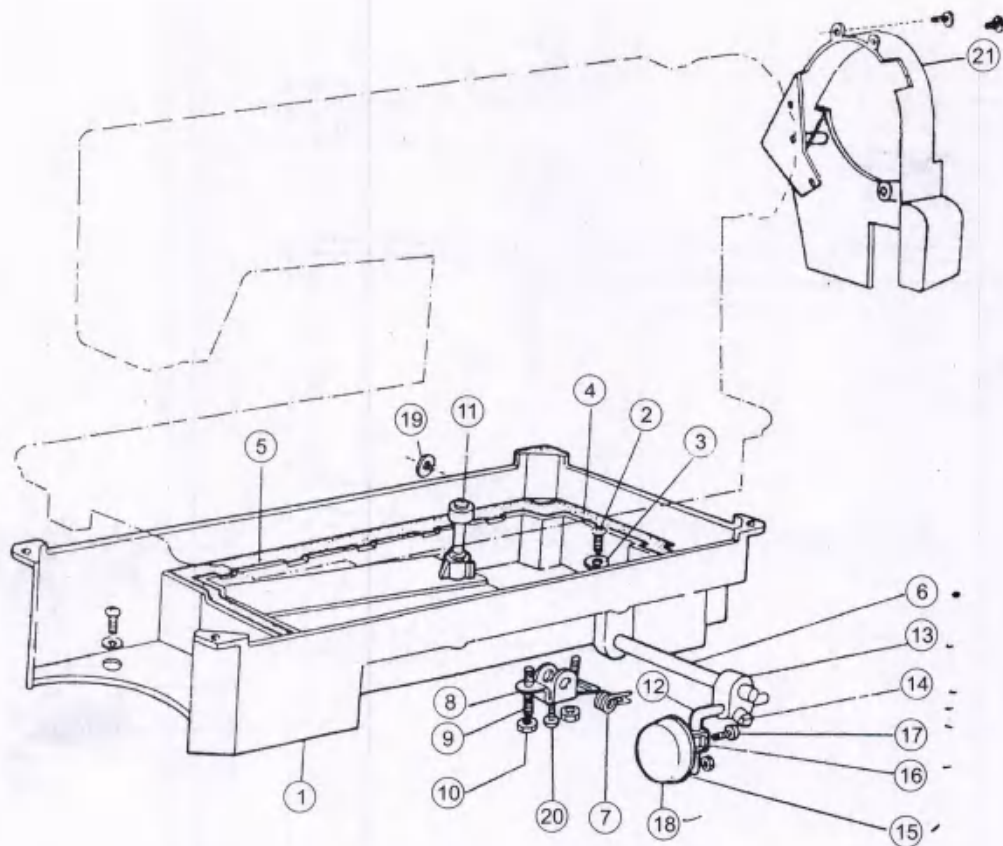

9. 油盘部件 OIL RESERVOIR COMPONENTS

序号 Ref.No	图号 Part No.	名称	Name	件数 Amt. Req.		
				M	H	B
1	124T9-001A1	油盘	Oil reservoir asm	1	1	1
2	22T9-001A2	放油螺钉	Oil drain screw	1	1	1
3	22T9-001A3	放油螺钉垫圈	Oil drain cap gasket	1	1	1
4	22T9001A4	油盘垫(小)	Gasket (big)	1	1	1
5	22T9-001A5	油盘垫(大)	Gasket (small)	1	1	1
6	22T9-001A6	膝控铰链轴	Knee press rod	1	1	1
7	22T9-001A7	膝控复位弹簧	Spring	1	1	1
8	22T9-001A8	膝控复位架	Knee-controlled throttling frame	1	1	1
9	22T9-001A9	膝控限位调节螺钉	Screw	2	2	2
10	22T9-001A10	调节螺钉	Nut	2	2	2
11	22T9-003B1	膝控提升顶杆	Knee-controlled lifting standing lever	1	1	1

序号 Ref.No	图号 Part No.	名称	Name	件数 Amt. Req.		
				M	H	B
12	22T9-003B2	膝控磁块弯杆	Knee-lifter plate rod	1	1	1
13	22T9-003B3	磁块弯杆接头	Bearing bracket	1	1	1
14	GB5781-86	磁块弯杆接头螺钉	Screw	2	2	2
15	22T9-003B5	膝控磁块	Knee press plate	1	1	1
16	22T9-003B6	磁块架	nee press plate frame	1	1	1
17	22T9-003B7	磁块架螺钉	Screw	1	1	1
18	22T9-003B8	磁块垫	Knee press plate cover	1	1	1
19	GB896-76	开口挡圈(挡圈O)	Thust ring	1	1	1
20	22T9-036	膝控限位架螺钉	Screw	1	1	1
21	22T9-004C	皮带罩组件	Belt cover asm	1	1	1

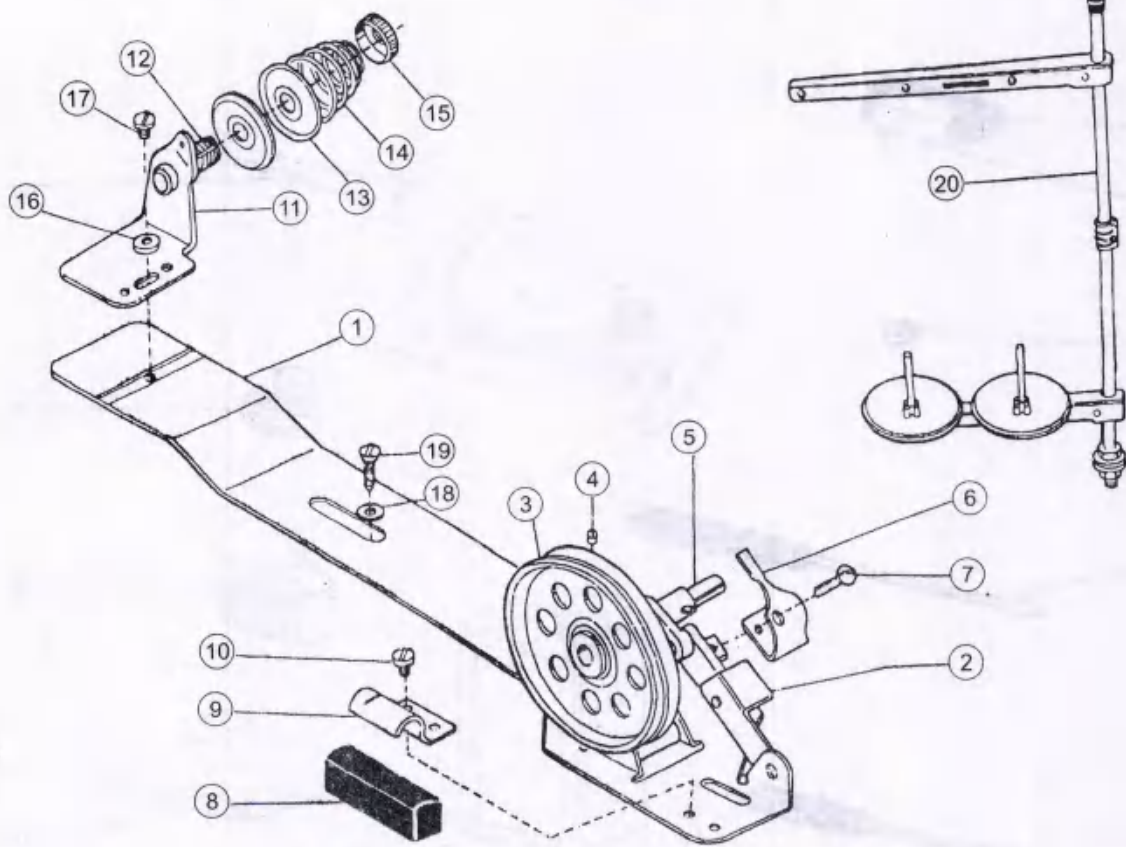

10. 绕线架、线架BOBBIN WINDER COMPONENTS

序号 Ref. No.	图号 Part No.	名称	Name	件数 Amt. Req.		
				M	H	B
1	6F0-001A	绕线器底座组件	Bobbin winder base asm	1	1	1
2	6F0-001A6a	绕线摆杆小组件	Bobbin winder swing lever asm	1	1	1
3	6F0-002	绕线轮	Bobbin winder asm	1	1	1
4	01/B112	绕线轮固定螺钉	Set screw	1	1	1
5	6F0-003	绕线轴	Bobbin winder shaft	1	1	1
6	6F0-004-1	清线踏板	Bobbin winder frame rod	1	1	
	6F0-004-2	清线踏板	Bobbin winder frame rod			1
7	6F0-005	清线踏板螺钉	Screw	1	1	1
8	6F0-006	制动块	Rubber brake stopper	1	1	1
9	6F0-007	制动块固定勾	Locating hook	1	1	1
10	6F0-008	制动块固定勾螺钉	Screw	1	1	1

序号 Ref. No.	图号 Part No.	名称	Name	件数 Amt. Req.		
				M	H	B
11	6F0-009B1B1	过线架	Thread tension bracket	1	1	1
12	17T7-017	过线架夹紧螺钉	Hinge screw	1	1	1
13	22T1-012F5	过线架夹线板	Tension disc	2	2	2
14	22T1-012F3	过线架夹线弹簧	Spring	1	1	1
15	J2.2.7	过线架夹线螺母	Tension stud-nut	1	1	1
16	BQ10021	过线架垫圈	Washer	1	1	1
17	22T2-004	过线架螺钉	Screw	1	1	1
18	BQ10021	绕线器木螺钉垫圈	Wood screw washer	2	2	2
19	GB99-76	绕线器木螺钉	Wood screw	2	2	2
20	GXJ-2	线架组件	Thread frame components	1	1	1

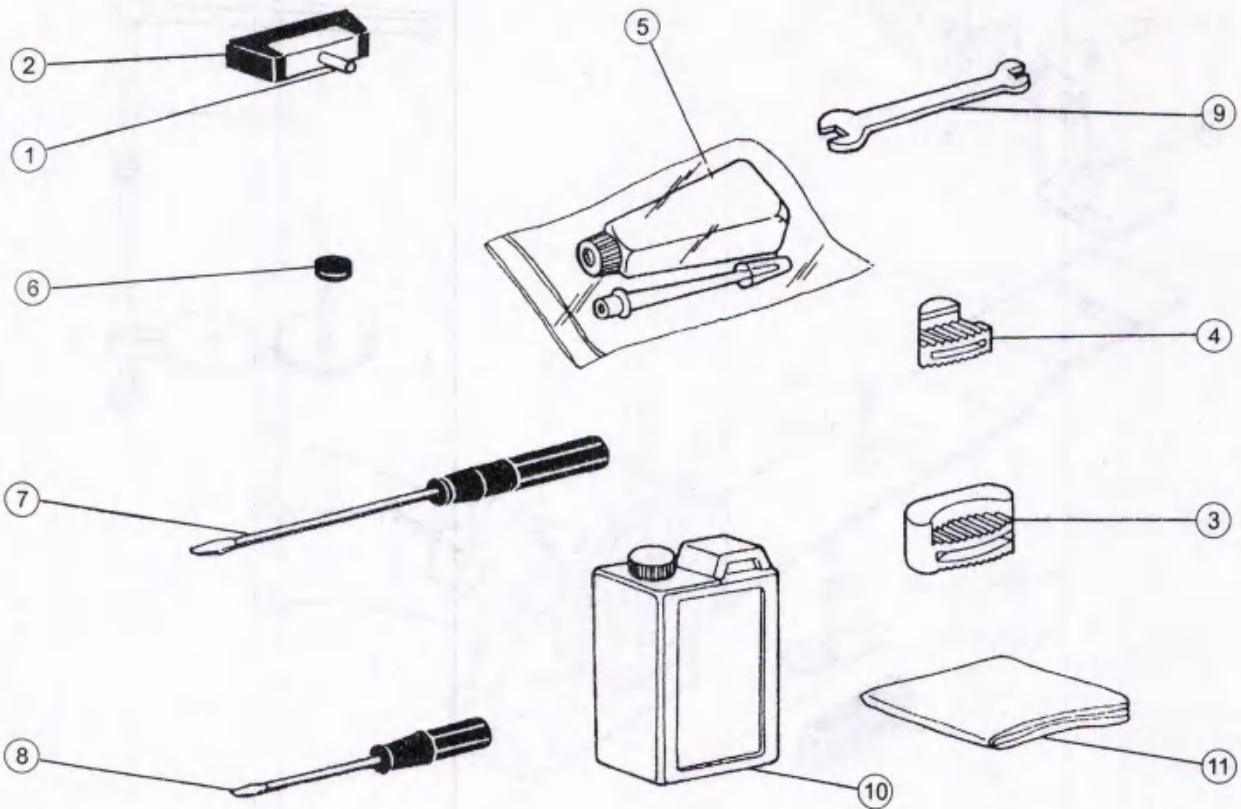

11. 附件ATTACHMENTS

序号 Ref.No	图号 Part No.	名称	Name	件数Amt.Req.		
				M	H	B
1	22T9-007F1	机壳铰链	Machine hinge	2	2	2
2	22T9-007F2	机壳铰链套	Machine hinge plate	2	2	2
3	22T9-009	机头防震垫块(大)	Vibration-proof cushion (big)	2	2	2
4	22T9-010	机头防震垫块(小)	Vibration-proof cushion (small)	2	2	2
5	22T9-011	小油壶	Small oil reservoir	1	1	1
6	22T9-012	磁块	Magnet	1	1	1

序号 Ref.No	图号 Part No.	名称	Name	件数Amt.Req.		
				M	H	B
7	22T9-013	螺钉起子(大)	Screw driver (big)	1	1	1
8	22T9-015	螺钉起子(小)	Screw driver (small)	1	1	1
9	22T9-016	双头扳手	Oil reservoir	1	1	1
10	22T9-017	油箱	Machine cloth cover	1	1	1
11	22T9-018	机罩		1	1	1
12	124T9-002	机头撑杆		1	1	1