

PART NO. EKT4032-561H

1 Electrical Characteristics

1.1 Technical Data

	Symbol	Value	Unit
Maximum allowable continuous AC voltage*1	VRMS	350.0	V
Maximum allowable continuous DC voltage	VDC	460.0	V
Varistor voltage Measured*2	VB	560(10%)	V
Typical capacitance value measured*3	C	200	pF
Typical capacitance value tolerance		±40	%
Maximum clamping voltage measured*4	VC	930	V
Rated peak single pulse transient current at *5	I P	2500	A

1.2 Reference Data

	Symbol	Value	Unit
Maximum Energy Absorption 10/1000µs	E	67.0	J
Response time	T _{rise}	<2	ns
Leakage current at V _{DC} (At initial state)	I _L	<30	µA
Leakage current at V _{DC} (After reliability Test)	I _{LA}	<100	µA
Operating ambient temperature		-45~+125	°C
Reflow temperature profile(Recommend)		260	°C

1.3 Other Data

Body	ZnO
End termination	Ag/Ni/Sn
Packaging	Bulk/Tape
Complies with Standard	IEC61000-4-5

1.4 Notes:

*1 AC voltage at 50~60Hz	Measured at 1mA DC
*2 Varistor voltage	Measured at f=1MHz, V _{rms} =0.5V
*3 Capacitance	Measured at 10A by 8/20µs Pulse
*4 Maximum clamping voltage	Measured by 8/20µs Pulse
*5 Rated peak single pulse transient current	Measured at 1mA DC

1.5 Storage Condition

- As far as possible, the components should be employed within 24 months after delivery from Kangtai Semiconductor.
- They should be left in their original packing to avoid soldering problems due to oxidized contacts.
- Storage temperature: - 25 up to + 45°C.
- Relative humidity: < 75 % annual average, < 95 % on max. 30 days in a year.

2 Type Code Designation

EKT
4032
—
561
H

①
②
③
④

- ① EKT: Logo
- ② 4032 : Chip size —4032 (10.0 x 8.0 mm) size
- ③ 561 : Varistor voltage(Breakdown voltage) - 560Vdc
- ④ H : High absorption

EKT PLASTIC CHIP VARISTORS

3 Dimensional drawings

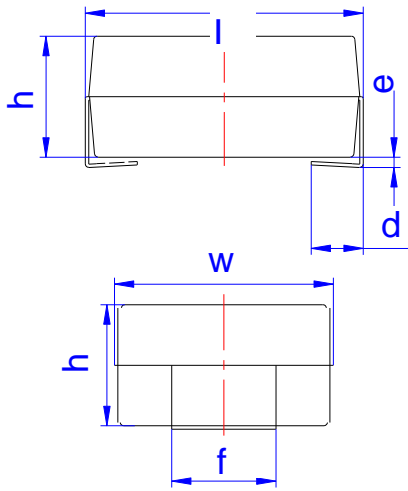

Ref.	Dimensions					
	Millimeters			Inches		
	Min.	Typ.	Max.	Min.	Typ.	Max.
l	10.1		10.7	0.398		0.421
w	7.7		8.3	0.303		0.327
h	3.6		4.5	0.165		0.189
d	1.2		1.8	0.047		0.071
e	0		0.3	0		0.012
f	2.7		3.3	0.106		0.130

4 Recommended solder pad layout

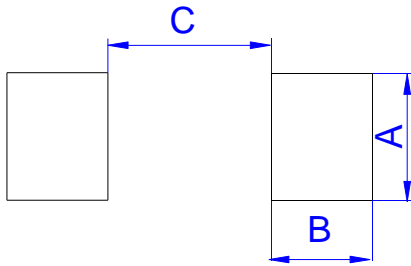

Ref.	Dimensions					
	Millimeters			Inches		
	Min.	Typ.	Max.	Min.	Typ.	Max.
A		3.5			0.138	
B		2.8			0.110	
C		6.5			0.265	

5 Soldering guidelines

The usage of mild, non-activated fluxes for soldering is recommended, as well as proper cleaning of the PCB.

The components are suitable for reflow soldering per JEDEC J-STD-020C

5.1 Wave soldering

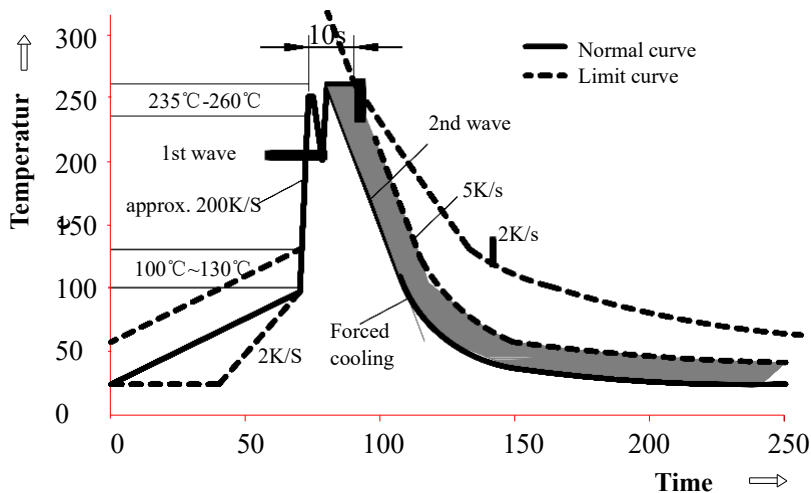

Temperature characteristics at component terminal with dual-wave soldering

5.2 Reflow soldering

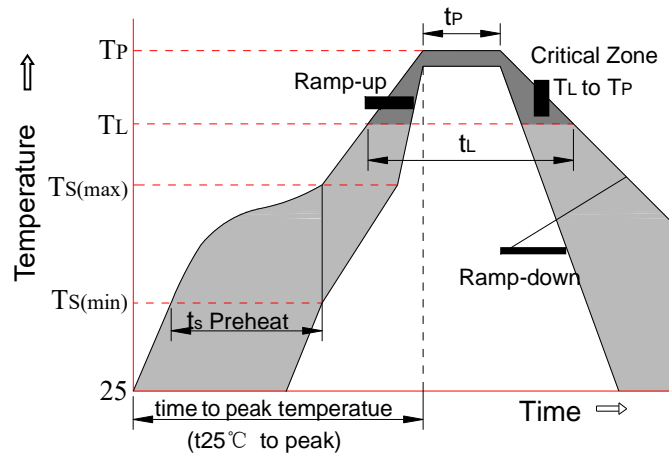

Profile feature		Sn-Pb assembly	Pb-Free assembly
Average ramp-up rate (TSmax to Tp)		3°C/sec. Max	3°C/sec. Max
Preheat	-Temperature min. (Ts(min))	+100°C	+150°C
	-Temperature max.(Ts(max))	+150°C	+200°C
	-Time (tSmin to tSmax)	60-120 secs.	60-180 secs.
Ts(max) to TL - Ramp-up Rate		3°C/sec. Max	3°C/sec. Max
Time maintained above	-Temperature min. (TL)	+183°C	+217°C
	-Time (tL)	60-150 secs.	60-150 secs.
Peak classification temperature (Tp)		+220°C to +240°C	+240°C to +260°C
Time within 5°C of actual peak temperature (tp)		10 secs. to 30 secs.	20 secs. to 40 secs.
Ramp-down rate		6°C/sec. max.	6°C/sec. max.
Time 25°C to peak temperature		6 min. max.	8 min. max.

Notes: All temperature refer to topside of the package, measured on the package body surface

Maximum number of reflow cycles: 3

6 Temperature derating curve

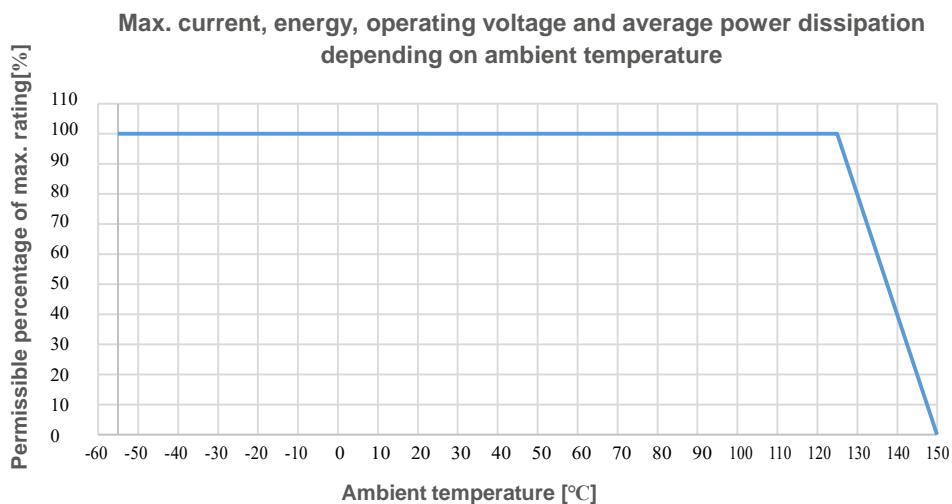

7 Taping and packaging Specification

7.1 Packaging Specification

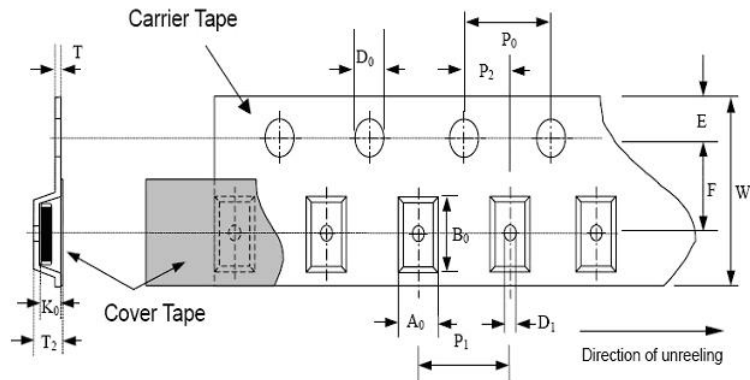

type	A_0 ± 0.20	B_0 ± 0.20	K_0 ± 0.10	T max	T_2 max	D_0 +0.05	D_1 ± 0.05	P_1 ± 0.10	P_2 ± 0.05	P_0 ± 0.1	W ± 0.30	E ± 0.10	F ± 0.05
3220	7.0	8.7	3.85	0.3	5.50	1.55	1.55	12.00	2.00	4.00	16.00	1.75	7.50
4032	8.4	10.8	3.85	0.3	5.50	1.55	1.55	12.00	2.00	4.00	24.00	1.75	11.50

7.2 reel dimension

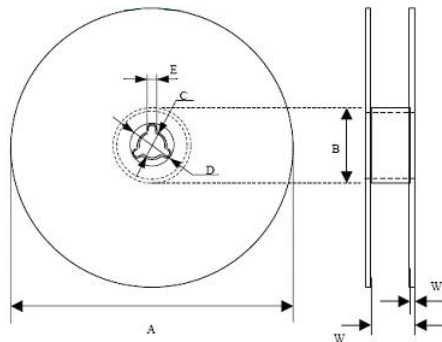

type	A	B	C	D	E	W	W_1
4032	330.0 ± 1.0	60.0 ± 0.5	13.0 ± 0.2	21.0 ± 0.2	2.0 ± 0.5	24.0 ± 0.3	2.3 ± 0.15

1) Quantity of taping packing(pcs): 1000